

AREA = 3,622.50 M<sup>2</sup>

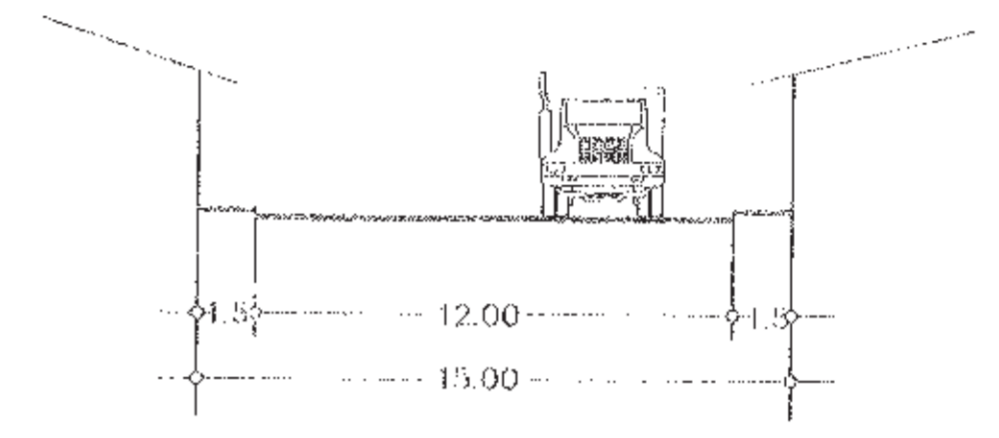

SECCION ACCESO PRINCIPAL

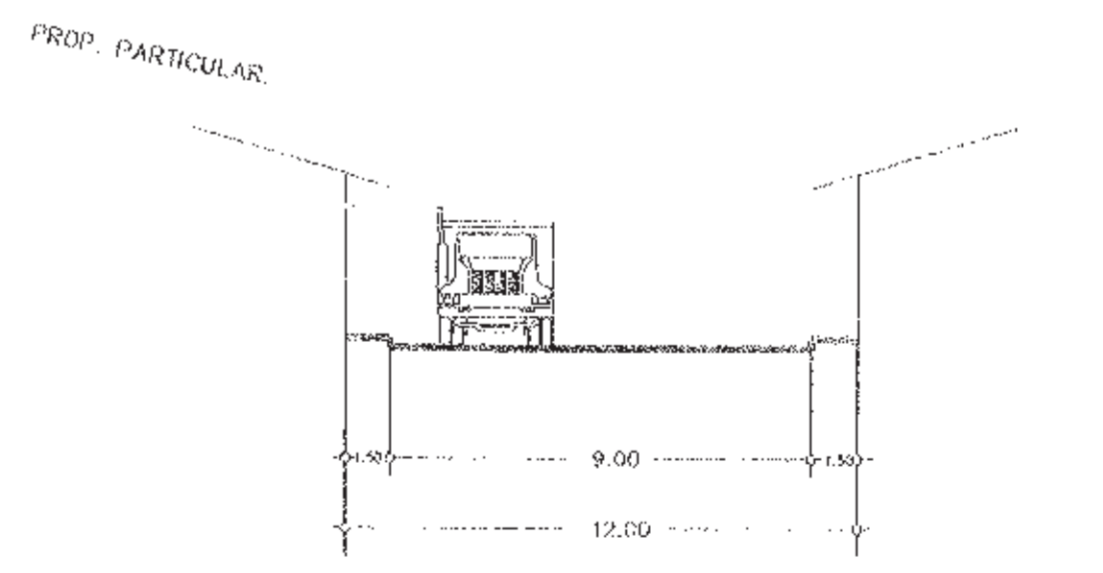

SECCION CALLES SECUNDARIAS



**PLANO APROBADO**  
 2003 - 2006  
 FECHA: 25/03/2002 No. DE FOLIO: 1052  
 DIRECCION DE FRACCIONAMIENTOS, CONDOMINIOS Y CONJUNTOS URBANOS.  
 2003 - 2006



**AREAS.**

MANZANA	No. DE LOTES	AREA M <sup>2</sup>
A	23	4,844.81 M <sup>2</sup>
B	70	15,987.60 M <sup>2</sup>
C	27	5,609.60 M <sup>2</sup>
D	31	9,783.24 M <sup>2</sup>
4 MNZS		
SUMA AREA VENDIBLE		36,225.25 M <sup>2</sup>
AREA CONACION	1	3,622.50 M <sup>2</sup>
TOTAL DE LOTES	151	
AREA DE VALIDADES		13,877.33 M <sup>2</sup>
AREA TOTAL		53,725.08 M <sup>2</sup>

CLAVE CATASTRAL: 5200-01-000-891  
 PROPIETARIO:

PROYECTO:  
**" RANCHO TETENAYO "**

UBICACION:  
 COL. VICENTE GUERRERO ATLATLHUACAN, MOR.

PLANO DE:  
**LOTIFICACION.**

FECHA: **MARZO 2002** ESCALA: **1:2000**  
 ACOTACION EN METROS.